

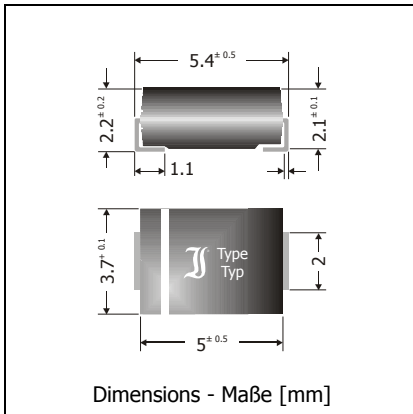

ER2A ... ER2M

Superfast Switching Surface Mount Si-Diodes Superschnelle Si-Dioden für die Oberflächenmontage

Version 2006-07-04



Nominal current – Nennstrom	2 A
Repetitive peak reverse voltage Periodische Spitzensperrspannung	50...1000 V
Plastic case Kunststoffgehäuse	~ SMB ~ DO-214AA
Weight approx. – Gewicht ca.	0.1 g
Plastic material has UL classification 94V-0 Gehäusematerial UL94V-0 klassifiziert	
Standard packaging taped and reeled Standard Lieferform gegurtet auf Rolle	

Maximum ratings

Grenzwerte

Type Typ	Repetitive peak reverse voltage Periodische Spitzensperrspannung V_{RRM} [V]	Surge peak reverse voltage Stoßspitzensperrspannung V_{RSM} [V]
ER2A	50	50
ER2B	100	100
ER2D	200	200
ER2G	400	400
ER2J	600	600
ER2K	800	800
ER2M	1000	1000

Max. average forward rectified current, R-load Dauergrenzstrom in Einwegschaltung mit R-Last	$T_T = 100^\circ\text{C}$	I_{FAV}	2 A
Repetitive peak forward current Periodischer Spitzenstrom	$f > 15$ Hz	I_{FRM}	10 A ¹⁾
Peak forward surge current, 50 Hz half sine-wave Stoßstrom für eine 50 Hz Sinus-Halbwellen	$T_A = 25^\circ\text{C}$	I_{FSM}	50 A
Rating for fusing, $t < 10$ ms Grenzlastintegral, $t < 10$ ms	$T_A = 25^\circ\text{C}$	i^2t	12.5 A ² s
Junction temperature – Sperrschichttemperatur	T_j		-50...+150°C
Storage temperature – Lagerungstemperatur	T_s		-50...+150°C

1 Max. temperature of the terminals $T_T = 100^\circ\text{C}$ – Max. Temperatur der Anschlüsse $T_T = 100^\circ\text{C}$

Characteristics
Kennwerte

Type Typ	Reverse recovery time Sperrverzugszeit t_{rr} [ns] ¹⁾	Forward voltage Durchlass-Spannung V_F [V] at / bei I_F [A]
ER2A...ER2D	< 35	< 1.0
ER2G	< 35	< 1.25
ER2J...ER2M	< 75	< 1.7

 Leakage current
Sperrstrom

 $T_j = 25^\circ\text{C}$
 $T_j = 100^\circ\text{C}$
 $V_R = V_{RRM}$
 $V_R = V_{RRM}$
 I_R
 I_R

 < 5 μA
 < 300 μA

 Thermal resistance junction to ambient air
 Wärmewiderstand Sperrschicht – umgebende Luft

 R_{thA}

 < 50 K/W ²⁾

 Thermal resistance junction to terminal
 Wärmewiderstand Sperrschicht – Anschluss

 R_{thL}

< 15 K/W

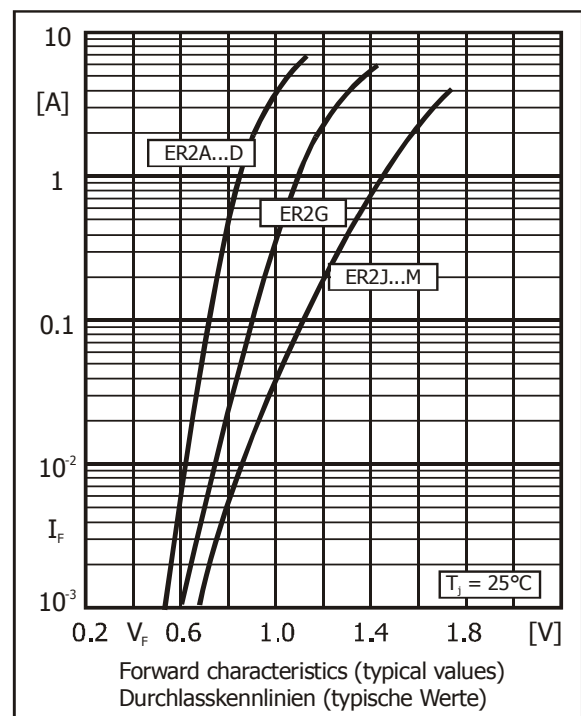
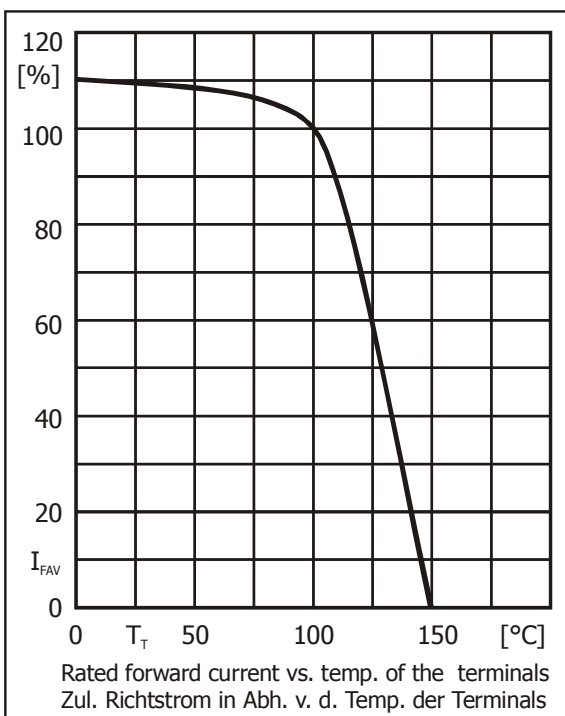

- $I_F = 0.5$ A through/über $I_R = 1$ A to/auf $I_R = 0.25$ A
- Mounted on P.C. board with 50 mm² copper pads at each terminal
 Montage auf Leiterplatte mit 50 mm² Kupferbelag (Löt-pad) an jedem Anschluss